

Emulatore pressione benzina per OPEL
Petrol pressure emulator for OPEL vehicles
Emulador pression gasolina para OPEL

Cod. 628126000

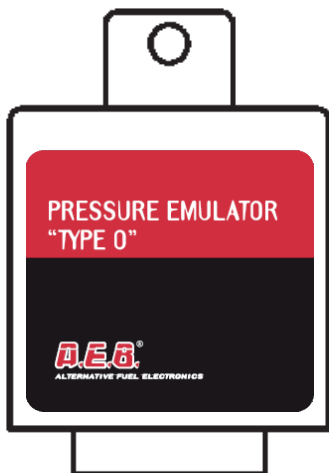

Manuale Istruzioni di Montaggio
Assembly Instruction Manual
Manual Instrucciones de Montaje

A.E.G.[®]
ALTERNATIVE FUEL ELECTRONICS

Indice - Index - Indice

ITALIANO

- Avvertenze generali 3
- Principio di funzionamento..... 4
- Vetture consigliate per l'installazione 4
- Garanzia 4
- Schema d'installazione Opel Astra 5
- Schema d'installazione Opel Antara 6

ENGLISH

- General warnings 7
- Principle functioning 8
- Vehicles recommended for installation of this unit..... 8
- Warranty 8
- Installation diagram Opel Astra 9
- Installation diagram Opel Antara 10

ESPAÑOL

- Advertencias generales 11
- Principio de funcionamiento 12
- Coches aconsejados para la instalación 12
- Garantía 12
- Esquema de instalación Opel Astra 13
- Esquema de instalación Opel Antara 14

Avvertenze generali



Installare in posizione verticale lontano da possibili infiltrazioni d'acqua.



Installare lontano da eccessive fonti di calore (es. collettori di scarico).



Installare lontano dalla bobina d'accensione e passare il cablaggio lontano dai cavi dell'alta tensione.



Realizzare delle buone connessioni elettriche evitando l'uso dei "rubacorrente".

Si tenga presente che la migliore connessione è la saldatura debitamente isolata.



Non aprire per nessun motivo la scatola dell'Emulatore, soprattutto con il motore in moto o il quadro inserito.

L'A.E.B. declina ogni responsabilità per danni a cose e persone derivati dalla manomissione del proprio dispositivo da parte di personale non autorizzato.

Principio di funzionamento

L'Emulatore codice 628126000 è stato progettato per simulare il corretto funzionamento del sensore di pressione benzina sulle vetture OPEL durante il funzionamento a GAS, evitando così problemi d'accensione della spia check-engine.

L'Emulatore s'inserisce durante il funzionamento a GAS e si disinserisce durante il funzionamento a BENZINA.

L'Emulatore può essere applicato solo sulle vetture riportate nell'elenco sottostante.

Vetture consigliate per l'installazione

- Opel Astra 1.4 turbo (A14NET).
- Opel Astra 1.6 (A16XER).
- Opel Antara 2.4 (LE5).

Garanzia

Il certificato di garanzia del prodotto è disponibile sul sito internet AEB (www.aeb.it) nella sezione prodotti/emulatori/628126000.

Schema d'installazione Opel Astra

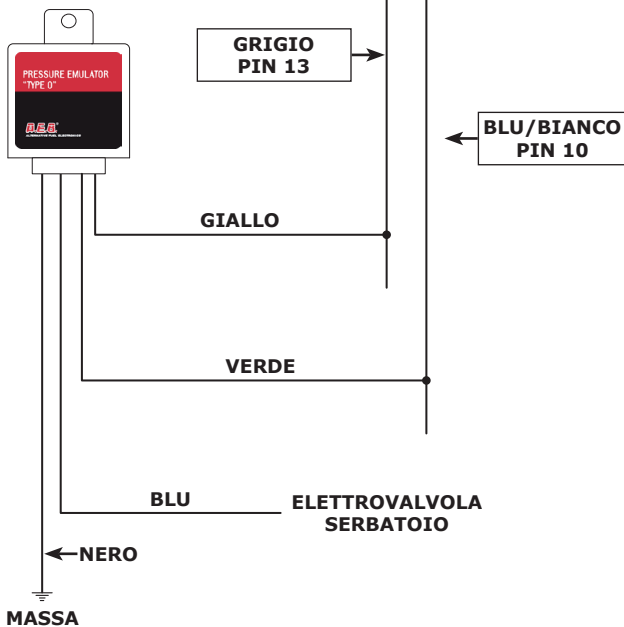

Schema d'installazione Opel Antara

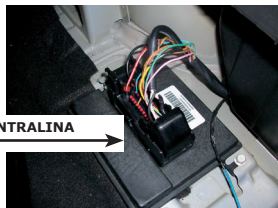
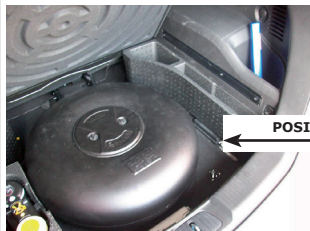

POSIZIONE CENTRALINA

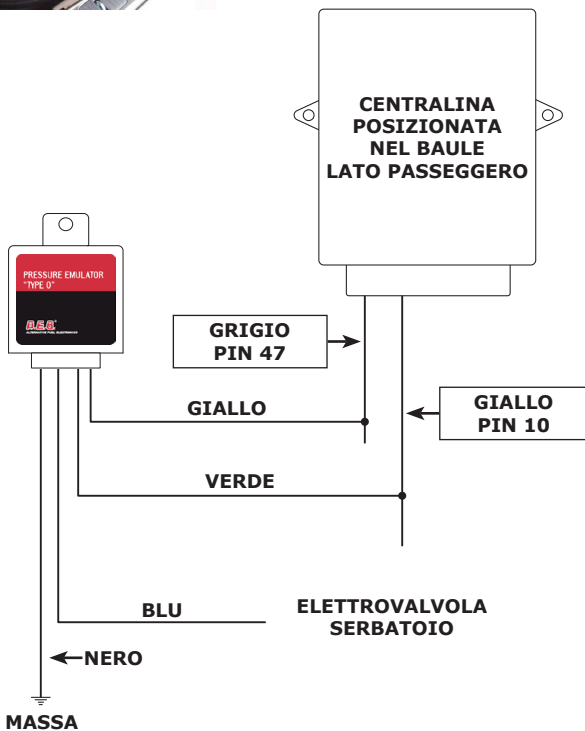

General warnings



Install in an upright position far from any possible infiltration of water.



Install far from any sources of excessive heat (eg. exhaust manifold).



Install far from the ignition coil and pass the wiring far from the high voltage cables.



Make good electrical connections without using a "current tap".

Bear in mind that the best connection is duly insulated welding.



Never open the processor box for any reason whatsoever, especially with the engine running or the panel switched on.

A.E.B. disclaims all liability for any damage or injury deriving from unauthorized personnel tampering with its device.

Principle functioning

The emulator code 628126000 is designed to simulate the proper operation of the petrol pressure sensor of the OPEL. This emulator function while the vehicle runs on gas and prevents the check-engine from activating.

The Emulator switches on during the GAS running and switches off during the GASOLINE running.

The Emulator can be fitted only on the vehicles mentioned in the following list.

Vehicles recommended for installation of this unit

- Opel Astra 1.4 turbo (A14NET).
- Opel Astra 1.6 (A16XER).
- Opel Antara 2.4 (LE5).

Warranty

The warranty certificate is available on the website AEB (www.aeb.it) in the products section/emulators/628126000.

Installation diagram Opel Astra

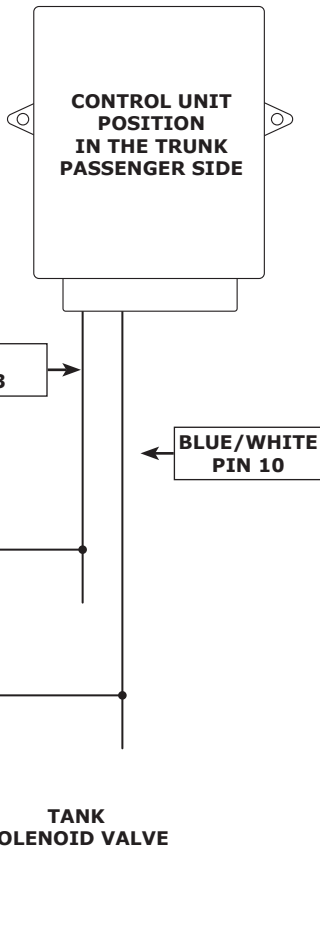

Installation diagram Opel Antara

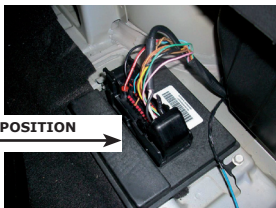

CONTROL UNIT POSITION

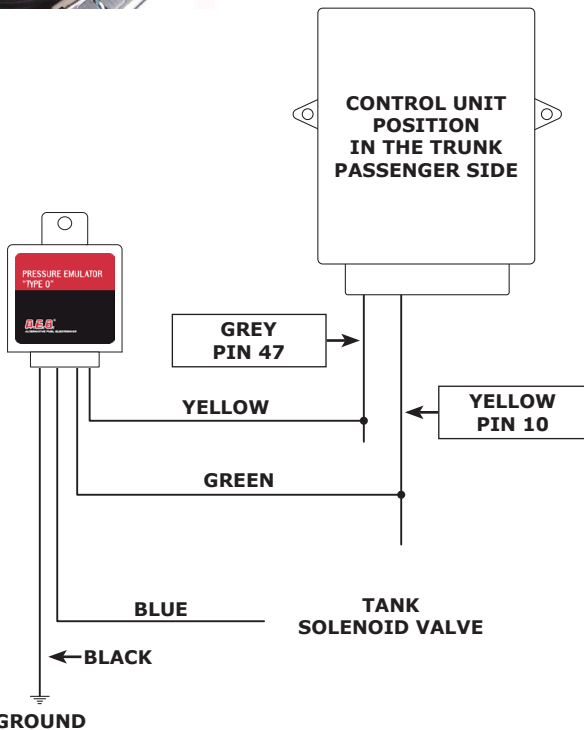

Advertencias generales



Instalar en posición vertical lejos de posibles infiltraciones de agua.



Instalar lejos de excesivas fuentes de calor (por ej. colectores de vaciado).



Instalar lejos de la bobina de encendido y pasar el cableado lejos de los cables de alta tensión.



Realizar buenas conexiones eléctricas evitando el uso del "robacorriente".

Hay que tener en cuenta que la mejor conexión es la soldadura debidamente aislada.



No abrir por ningún motivo la caja del Emulador, sobre todo con el motor en marcha o el cuadro conectado.

A.E.B. declina toda responsabilidad por daños a personas o cosas derivados de la manipulación del dispositivo por parte de personal no autorizado.

Principio de funcionamiento

El emulador código 628126000 ha sido proyectado para simular el correcto funcionamiento del sensor de presión de combustible sobre los vehículos OPEL durante el funcionamiento a GAS, evitando de esta manera problemas de encendido de las luz check-engine.

El emulador se activa durante el funcionamiento a GAS y se desactiva durante el funcionamiento a GASOLINA.

El emulador puede ser aplicado solamente sobre los vehículos detallados en el elenco presentado a continuación.

Coches aconsejados para la instalación

- Opel Astra 1.4 turbo (A14NET).
- Opel Astra 1.6 (A16XER).
- Opel Antara 2.4 (LE5).

Garantía

El certificado de garantía está disponible en la página web AEB (www.aeb.it) en los productos section/emuladores/628126000.

Esquema de Montaje Opel Astra

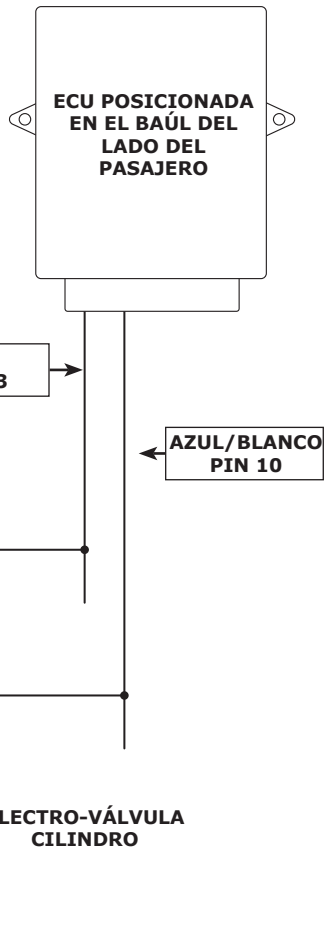

Esquema de Montaje Opel Antara

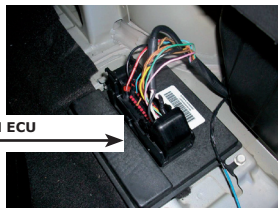
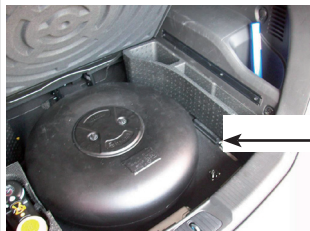

POSICIÓN ECU

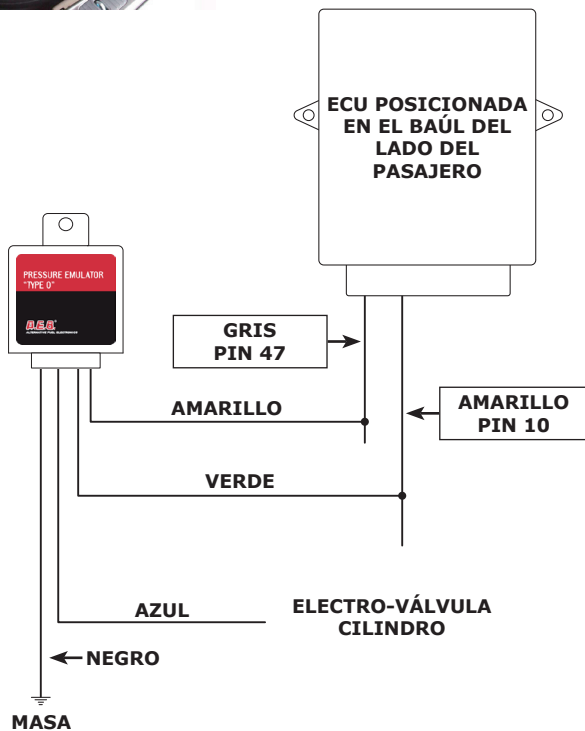



ALTERNATIVE FUEL ELECTRONICS

**Via dell'Industria, 20
(Zona Industriale Corte Tegge)
42025 CAVRIAGO (RE) ITALY
Tel . (+39) 0522 494401 r.a.
Fax (+39) 0522 494410
<http://www.aeb.it>
E-mail: info@aeb-tech.com
E-mail: aebasst@aeb-tech.com**